

# USER MANUAL

Foundation Fieldbus



IHP24-A  
IHP24-AF  
IHP24-BF



## Table of contents

<b>1</b>	<b>General.....</b>	<b>3</b>
1.1	Safety instructions .....	3
<b>2</b>	<b>Purpose .....</b>	<b>4</b>
<b>3</b>	<b>Specifications.....</b>	<b>5</b>
3.1	Electrical specifications for standard configuration .....	5
3.2	Power Ratings.....	5
3.2.1	FF – Fieldbus Connector.....	6
3.2.2	Terminals .....	6
3.3	Additional IHP24 FF-Fieldbus Menu Function.....	6
3.4	Additional IHP24 FF-Fieldbus Error Codes.....	6
<b>4</b>	<b>FF - Fieldbus Function Blocks inside the Val Controls Device .....</b>	<b>7</b>
4.1	Transducer block .....	8
4.2	FF - Function blocks used in Default Setting.....	9
4.3	FF – Other Function blocks available but not used in default setting. ....	12
<b>5</b>	<b>Appendix – NI-FBUS Configurator Tool .....</b>	<b>15</b>
5.1	DD File .....	15
5.2	Import DD Files.....	15
5.3	Upload data to NI-FBUS from the device. ....	15
5.4	Changing Node ID from NI-FBUS .....	16
5.5	Modifying Device Tag name.....	16
5.6	Modifying Block Tags names .....	16
5.7	Factory Reset of the device. ....	16
<b>6</b>	<b>Appendix – Function Blocks Description .....</b>	<b>17</b>
6.1	Appendix - Resource (RB2) Block.....	17
6.2	Appendix - Transducer Block (MTB) .....	25
6.3	Appendix - Analogue Input Function Block (AI) .....	34
6.4	Appendix - Analogue Output Function Block (AO) .....	44
6.5	Appendix - Discrete Input Function Block (DI).....	51
6.6	Appendix - Discrete Output Function Block (DO) .....	53
6.7	Appendix - PID Function Block (PID).....	55
<b>7</b>	<b>Trouble Guide .....</b>	<b>56</b>
7.1	Check “Err Lock Result” .....	56
<b>8</b>	<b>Important Issues .....</b>	<b>57</b>
8.1	Limitation in use of Factory Reset in NI-FBUS.....	57
8.2	Always upload configuration before configuration.....	57
8.3	Don’t remove power when updating configuration.....	57
8.4	Don’t use the MTB Transducer block, in Function block Application .....	57

## 1 General

This manual covers software version:

Software ID: DHP-SW-009  
Software Version: 1.06.04

Foundation Fieldbus software

Software ID: DHP-SW-013  
Software Version: 1.00

DD file

Software ID: DHP-SW-011  
Software Version: 1.00

### 1.1 Safety instructions

For a safe installation of a positioner, the following must be observed. The module must only be installed by qualified personnel who are familiar with the national and international laws, directives and standards that apply to this product as well as all instructions in this manual.

The information in this user manual is subject to changes without notice.

## 2 Purpose

It is the purpose of this document, to list specifications, protocol commands and functions in the Foundation Fieldbus communication protocol in Val Controls products.

### 3 Specifications

#### 3.1 Electrical specifications for standard configuration

<b>FF-Fieldbus</b>	
Interface	FF-Fieldbus - H1 Device Class – Basic Device
Termination	No internal termination
Baud rate	31250 baud
Field bus ID (Node ID)	Node ID 17 – 36 and 223 - 247 Software selectable Default Node ID 247
Default Tag Name	“Val Controls” can be changed.
Execution Time	<ul style="list-style-type: none"> <li>- AI 25 ms</li> <li>- AO 31.25 ms</li> <li>- DI 25 ms</li> <li>- DO 25 ms</li> <li>- PID 31.25 ms</li> <li>- RATIO 31.25 ms</li> <li>- BG 25 ms</li> <li>- SC 25 ms</li> <li>- ISEL 25 ms</li> <li>- LLAG 25 ms</li> </ul>
PD_TAG = Modbus_FF Manufacture Id = 0x000105 hex - Microcyber Inc Device Type = 0x1001 hex DEV-Rev = 0x01 hex DD-Rev=0x01 hex CF-Rev = 0x01 hex ITK-Rev = 5.00	
DD-File - Tested on the following systems <ul style="list-style-type: none"> <li>- Emerson Delta V version 8.4.2</li> <li>- Yokogawa Centum VPR 5.01</li> <li>- Honeywell, Experion control system revision 400.2</li> </ul>	

#### 3.2 Power Ratings

<b>FF-Fieldbus – H1</b>
Power Requirements: 9-32 V
Current Consumption: < 5mA

### 3.2.1 FF – Fieldbus Connector

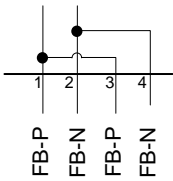

### 3.2.2 Terminals

See the chart below to see how to connect to the terminals on the positioner.  
1+3 and 2+4 is internally connected.

FF-Fieldbus	
1.	FB-P Receive/transmit data line, positive polarity
2.	FB-N Receive/transmit data line, negative polarity
3.	FB-P Receive/transmit data line, positive polarity
4.	FB-N Receive/transmit data line, negative polarity

### 3.3 Additional IHP24 FF-Fieldbus Menu Function

Internally in IHP24 there is a hardware Foundation Fieldbus module. This module communicates with the rest of the hardware in IHP24 via a local Modbus interface. This interface needs to run at a fixed setup ID = 1, Baud rate = 38400, Parity = Even, Stop bits = 1. The communication settings should always be set to these values.

It is important to set the Baud rate after an “Advanced Reset” of the IHP24.

Advanced menu	Default	Value	Reset	Description
6 Modbus				Modbus configuration
1 ID	1	1-247	A	Change the Modbus node ID
2 Baudrate	57600	9600/38400/57600	A	Change the baudrate
3 Parity	Even	None/Even/Odd	A	Change the parity
4 Stopbits	1	1-2	A	Change the number of stopbits

### 3.4 Additional IHP24 FF-Fieldbus Error Codes

No. 801	Fieldbus_OutOfService
Description	Fieldbus AO block out of service. Mode Block is “OOS” Set the Mode Block to “Auto” or “Cascade”  The device goes to its hardware fail position. All solenoids are de-energized.
Trouble shooting	Set the Device in In Service  Or check the Internal Modbus Menu parameter settings. ID = 1, Baud rate = 38400, Parity = Even, Stop bits = 1.

## 4 FF - Fieldbus Function Blocks inside the Val Controls Device

This section contains the supported FF-Fieldbus commands.

The following FF-Fieldbus blocks are available:

- Resource Block (RB2)
- Modbus Transducer Block (MTB)
- Analogue Input Block (AI)
- Analogue Output Block (AO)
- Discrete Input Block (DI)
- Discrete Output Block (DO)
- PID Regulator (PID)

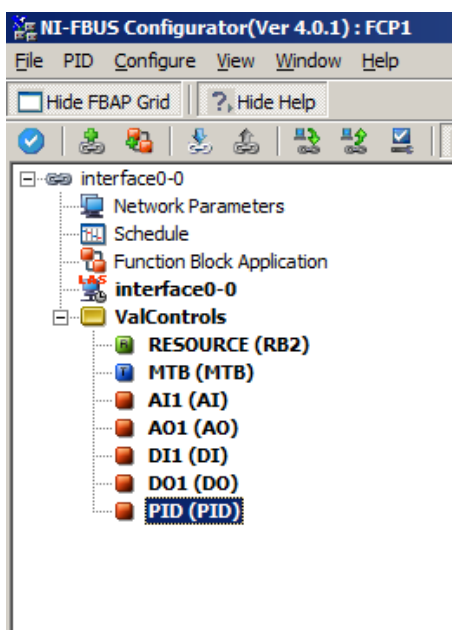

### Resource (RB2)

Resources block, used to describe the characteristics of field devices, such as device name, manufacturer, serial number. There is no input or output parameter for resource block.

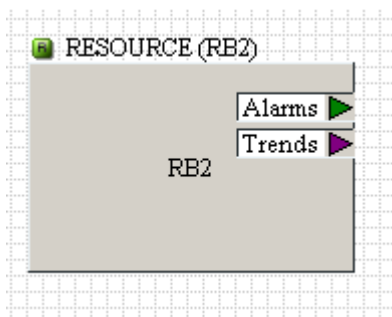

## 4.1 Transducer block

### Transducer Block (MTB)

Analogue and Digital input and output parameters are stored in the MTB Transducer Block. This block is linking the Hardware and the Fieldbus Analogue and Discrete Input and Output functions.

Values in this block should not be changed.

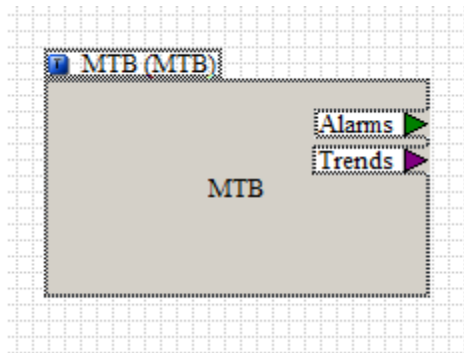



## 4.2 FF - Function blocks used in Default Setting.

### Analogue Input (AI)

Analog input function block, used to receive input data from the transducer blocks (MTB). Other function blocks can then read the value from the “OUT” port.

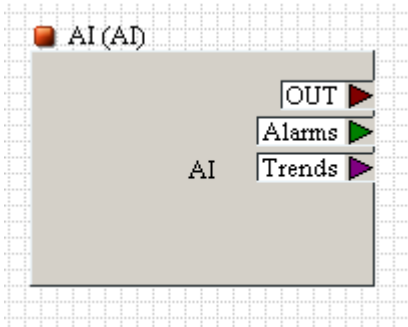

In the Default setting:

The “OUT” contains the actual position signal from the Val Controls Device. Values 0.00 to 100.00%

### Configuration

If you want to change the sensor input just change the CHANNEL register in the AI Block.

Block	Signal in Device	OUT Value	Status
AI1	TM – Flow %	0.00% - 100.00%	Good / Bad

### Error Handling

If the IHP24 status is “Ok”, FF-Fieldbus status on the AI channel goes to “Good”

If the IHP24 status is “Error”, FF-Fieldbus status on the AI channel goes to “Bad”

## Analogue Output (AO)

Analog output function block, used to transmit output data to transducer block, acting on the physical device.

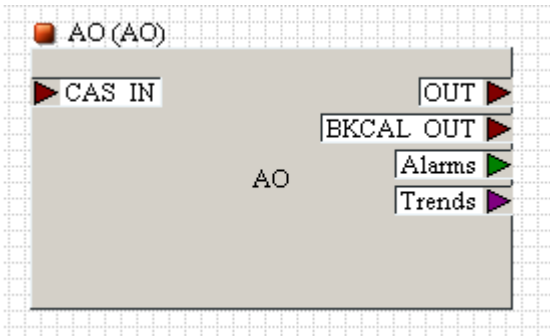

In the Default setting:

In “Cascade Mode” the Val Controls Device gets its SP ( Setpoint ) from the “CAS\_IN” Input. Values of the “CAS\_IN” should be in the range from “0.00% - 100.00%”

“OUT” contains the same value as “CAS\_IN”

### Configuration

Block	Signal in Val Controls	CAS_IN Values:
AO.OUT	SP – Flow %	0.00% - 100.00%

## Fail position in Cascade Mode

If the Val Controls Device receives the status bad from the fieldbus, the device goes to its fail position. The fail position is determined depending on configuration.

Example showing what will happen on the AO.OUT when one of the following errors occurs.

### Fault Causes

- AO.CAS\_IN.STATUS signal has status BAD
- Connection to SPUR is broken

### Configuration

- AO.IO\_OPTS, can be set to “0” (Disabled) or “Fault state to value”
- AO.FSTATE\_VAL, the fail position 0.0% - 100.0%

### Control Signal

- AO.CAS\_IN – In cascade Mode

### Output Signal

- AO.OUT → Control signal SP-FLOW in Val Controls Device.

### AO Block Mode - Cascade

AO.CAS_IN value (0.0-100.0%)	AO.CAS_IN Status	SPUR	AO.IO_OPTS (Fail function)	AO.FSTATE_VAL (Fail position)	AO.OUT Result
67.0%	Good	Connect	0	0.0%	67.0%
67.0%	Bad	Connect	0	0.0%	67.0%
67.0%	Good	Connect	Fault state to value	0.0%	67.0%
67.0%	Bad	Connect	Fault state to value	0.0%	0.0%
67.0%	Good	Broken	0	0.0%	67.0%
67.0%	Bad	Broken	0	0.0%	67.0%
67.0%	Good	Broken	Fault state to value	0.0%	0.0%
67.0%	Bad	Broken	Fault state to value	0.0%	0.0%

### AO Block Mode - OOS

Fieldbus AO block out of service.

The device goes to its hardware fail position. All solenoids are de-energized. Error Code 801 is logged.

### 4.3 FF – Other Function blocks available but not used in default setting.

#### Discrete Input (DI)

Discrete input function block, used to receive input data of transducer blocks, and transmit it to other function blocks.

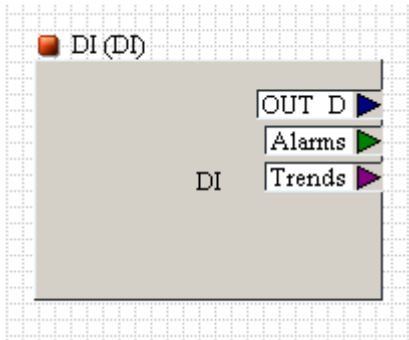

#### Configuration

If you want to change the digital input just change the CHANNEL register in the DI Block.

Block	Signal in Device	OUT_D Values:	Status
DI1			

Note: No signals are available on any of the channels.

## Discrete Output (DO)

Discrete output function block, used to transmit discrete output data to transducer block.

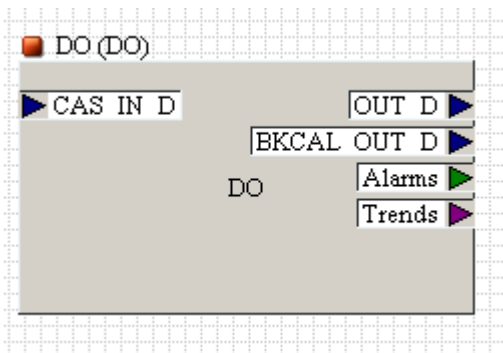

## Configuration

Block	Signal in Device	CAS_IN D Values:	Status
DO1			

Note: No signals are available on any of the channels.

## PID (PID)

PID function block, is a position automatic control module. It zooms in or out for deviation and accumulates. It includes a variety of functions, such as set-point adjustment, process parameters (PV) filtering, feed forward and output tracking, etc.

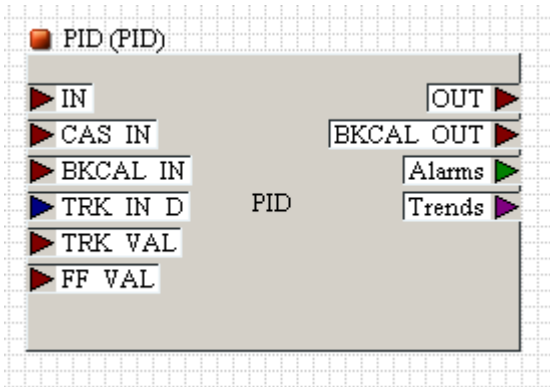

---

## 5 Appendix – NI-FBUS Configurator Tool

### 5.1 DD File

NI-FBUS Configurator Rev 4 is a tool that can be used to configure the Fieldbus Interface used by the Val Controls Device.

First you should be sure that the interface is installed in NI-FBUS.

### 5.2 Import DD Files

In windows

Select [National Instruments / NI-FBUS / Utilities / Interface Configuration Utility]

- If the Interface Configuration Utility will not start, stop the NI-FBUS process.

In windows go to “Task Manager”, and end the “nifb.exe” process.

On the start-up window

- Press Import DD/CFF
- Browse the location for the files, open 000105, open 1001, open 0101.ffa
- Press Ok, .. the DD files is imported successfully
- Browse the location for the files, open 000105, open 1001, open 010101.cff
- Press Ok, .. the DD files is imported successfully

Now start the NI-FBUS configurator

Select [National Instruments / NI-FBUS / NI-FBUS Configurator]

Now NI-FBUS is configured to recognise the Val Controls Fieldbus Device.

### 5.3 Upload data to NI-FBUS from the device.

First start the NI-FBUS Configurator if not already started. If the application does not start, check that the PC is connected to the Fieldbus Network.

In the network there should be a “ValControls” device.

- Click on ‘Device Tag Name’ in the tree window.
- In the menu select ‘Configure’.
- Choose ‘Upload Configuration.’
- Press ‘Yes’
- .. now its uploading data from the device to NI-FBUS Configurator.

---

## 5.4 Changing Node ID from NI-FBUS

If you need to change the Fieldbus Node ID address then you should do it now.

- Click on ‘ValControls’ in the tree window.
- In the menu select ‘ValControls’.
- Choose ‘Set Address’.
- Press ‘Yes’ if you get a warning
- Now you can set the Address in between 17 – 36 and 223 - 247

## 5.5 Modifying Device Tag name

If the default tag names “ValControls” conflicts with the other tag names in the network, they can be modified with the NI-FBUS tool.

## 5.6 Modifying Block Tags names

If the default tag names “AI” .. “AO” conflicts with the other tag names in the network, they can be modified with the NI-FBUS tool.

## 5.7 Factory Reset of the device.

Do not make a factory reset of the device, since it will reset all parameters in the MTB transducer block and all TAG names and Node ID address.



## 6 Appendix – Function Blocks Description

### 6.1 Appendix - Resource (RB2) Block

Resource (RB2) Block			
Label / Name / Handling	Group	Idx rel.	Description / Format
ST_REV	[Others]	1	<p>Length: 2 bytes Read Only Value: 0 – initial value</p> <p>Description: The revision level of the static data associated with the function block. The revision value will be incremented each time a static parameter value in the block is changed</p>
TAG_DESC	[Process]	2	<p>Length: 32 bytes Value: “ ”</p> <p>Description: The user description of the intended application of the block.</p>
STRATEGY	[Others]	3	<p>Length: 2 bytes Value: 0</p> <p>Description: The strategy field can be used to identify grouping of block. This data is not checked or processed by the block</p>
ALERT_KEY	[Alarms]	4	<p>Length: 1 byte</p>
MODE_BLK	[Process] [Diagnostic]	5	<p>Length: 4 bytes 1:Target – Value: OOS 2:Actual –Value: OOS 3:Permitted – Value: Auto   OOS 4:Normal – Value: Auto</p> <p>Description: The actual target permitted and normal modes of the block.</p> <p>Target: This is the mode requested by the operator. Only one mode from those allowed by the permitted mode parameter may be requested.</p> <p>Actual: This is the current mode of the block which may differ from the target based on operating conditions. Its value is calculated as a par of block execution</p> <p>Permitted: Defines the modes which are allowed for an interface of the block. The permitted mode</p>

			is configured based on application requirement.
BLOCK_ERR	[Diagnostic]	6	<p>Length: 2 bytes</p> <p>Description: This parameter reflects the error associated with the hardware or software components associated with a block. It is a bit string so that multiple errors may be shown.</p>
RS_STATE	[Process]	7	<p>Length: 1 bytes Value: Standby</p> <p>Description: State of the function block application state machine</p>
TEST_RW	[Process]	8	<p>Read Write</p> <p>Value_1 Value_2 Value_3 Value_4 Value_5 Value_6 Value_7 Value_8 Value_9 Value_10 Value_11 Value_12 Value_13 Value_14 Value_15</p> <p>Description: Read/Write Test parameters – used only for conformance testing</p>
DD_RESSOURCE	[Others]	9	<p>Length: 32 bytes Read Only Value: “ ”</p> <p>Description: String identifying the tag of the resource which contains the Device Description for this resource.</p>
MANUFAC_ID	[Diagnostic]	10	<p>Value: “0x000105” – Microcyber Inc Length: 4 bytes Read Only</p> <p>Description: Manufacturer identification number – used by an interface device to locate the DD file for the</p>

			resource
DEV_TYPE	[Diagnostic]	11	<p>Value: "0x1001" – NCS_MODBUS_FF          Length: 2 bytes          Read Only</p> <p>Description:          Manufacturer's model number associated with the resource – used by the interface defines to locate DD file for the resource</p>
DEV_REV	[Diagnostic]	12	<p>Value: "0x02"          Length: 1 bytes          Read Only</p> <p>Description:          Manufacturer's revision number associated with the resource – used by the interface defines to locate DD file for the resource</p>
DD_REV	[Diagnostic]	13	<p>Value: "0x01"          Length: 1 bytes          Read Only</p> <p>Description:          Revision of the DD associated with the resource – used by an interface device to locate the DD file for the resource.</p>
GRANT_DENY	[Options]	14	<p>1: Length: 1 bytes          Read Write</p> <p>2: Length 1 bytes          Read Write</p> <p>Description: Option for controlling access of host computers and local control panels to operating tuning and alarm parameters of the block.</p>
HARD_TYPES	[Process]	15	<p>Length: 2 bytes          Read Write</p> <p>Description: The types of hardware available as channel numbers</p>
RESTART	[Options]	16	<p>Length: 1 bytes          Read Write</p> <p>Allows a manual restart to be initiated. Several degrees of restart are possible, they are:</p> <p>1: Run – Normal state when running          2: Restart Resource          3: Restart with Default – Set the parameters to</p>

			<p>INITIAL VALUES.</p> <p>4: Restart Processor – perform a warm start-up</p> <p>Description: Allows a manual restart to be initiated. Several degrees of restart are possible. See above.</p>
FEATURES	[Options]	17	<p>Length: 2 bytes</p> <p>Read Only</p> <p>Description: Used to show supported resource block options</p>
FEATURES_SEL	[Options]	18	<p>Length: 2 bytes</p> <p>Read Write</p> <p>Description: Used to select resource block options</p>
CYCLE_TYPE	[Tuning]	19	<p>Length: 2 bytes</p> <p>Read Only</p> <p>Description: Identifies the block execution methods available for resource.</p>
CYCLE_SEL	[Others]	20	<p>Length: 2 bytes</p> <p>Read Write</p> <p>Value: 0x0000</p> <p>Description: Used to select the block execution methods for this resource.</p>
MIN_CYCLE_T	[Process]	21	<p>Length: 4 bytes</p> <p>Read Only</p> <p>Description: Time duration of the shortest cycle interval of witch the resource is capable. 0 1/32mSek</p>
MEMORY_SIZE	[Others]	22	<p>Length: 2 bytes</p> <p>Read Only</p> <p>Value: 512 Kbyte</p> <p>Description: Available configuration memory in the empty resource. To be checked before attempting a download</p>
NV_CYCLE_T	[Process]	23	<p>Length: 4 bytes</p> <p>Read Only</p> <p>Description: Interval between writing copies of NV parameters to non-volatile memory. Zero means Never. 0 1/32mSek</p>
FREE_SPACE	[Diagnostic]	24	<p>Length: 4 bytes</p> <p>Read Only</p>

			<p>Value: 77%</p> <p>Description: Range 0-100% Percent of memory available for buffer configuration. Zero in a pre-configurable device</p>
FREE_TIME	[Diagnostic]	25	<p>Length: 4 bytes Read Only Value: 0%</p> <p>Description: Range 0-100% of the block processing time that is free to process additional blocks.</p>
SHED_RCAS	[Others]	26	<p>Length: 4 bytes Read Write Value: 640000 1/32 millisecond</p> <p>Description: Time duration at which to give up an computer writes to function block RCas locations</p>
SHED_ROUT	[Others]	27	<p>Length: 4 bytes Read Write Value: 640000 1/32 millisecond</p> <p>Description: Time duration at which to give up on computer writes to function block Rout locations</p>
FAULT_STATE	[Options]	28	<p>Length: 1 bytes Read Only</p> <p>Value: Clear</p> <p>Condition set by loss of communication to an output block, failure promoted to an output block or a physical contact. When fault state condition is set then output function blocks will perform there FSTATE actions.</p>
SET_FSTATE	[Options]	29	<p>Length: 1 bytes Read Write Value: Off</p> <p>Description: Allows the fault state condition to be manually initiated by selecting Set.</p>
CLR_FSTATE	[Options]	30	<p>Length: 1 bytes Read Write Value: Off</p> <p>Description: Writing a Clear to this parameter will clear the device fault state if the field condition if any has cleared.</p>
MAX_NOTIFY	[Alarms]	31	<p>Length: 1 bytes</p>

			Read Only Value: 5  Description: Maximum number of unconfirmed alert notify messages possible.
LIM_NOTIFY	[Alarms]	32	Length: 1 bytes Read Write Value: 5  Description: Maximum number of unconfirmed alert notify messages allowed.
CONFIRM_TIME	[Alarms]	33	Length: 4 bytes Read Write Value: 64000 1/32 millisecond  Description: The minimum time between retries of alert reports
WRITE_LOCK	[Process][Options]	34	Length: 1 bytes Read Write  Value: Not Locked  Description: If set, no writes from anywhere are allowed except to clear write lock. Block inputs will continue to update.
UPDATE_EVT	[Others]	35	1 Unacknowledged: Length: 1 bytes Read Write  2 Update State: Length: 1 bytes Read Only  3 Time Stamp: Length: 8 bytes Read Only  4 Static Revision: Length: 2 bytes Read Only  Relative Index: Length: 2 bytes Read Only  Description: This alert is generated by any change to the static data.
BLOCK_ALM	[Others]	36	1: Unacknowledged

			<p>Length: 1 bytes Read Write</p> <p>2: Alarm State Length: 1 bytes Read Only</p> <p>3: Time Stamp Length: 8 bytes Read Only</p> <p>4: Sub code Length: 2 bytes Read Only</p> <p>5: Value Length: 1 bytes Read Only</p> <p>Description: The block alarm is used for all configuration hardware connected failure or system problems in the block. The cause of the alert is entered in the sub code field.</p>
ALARM_SUM	[Others]	37	<p>1: Current Length: 2 bytes Read Only</p> <p>2: Unacknowledged Length: 2 bytes Read Only</p> <p>3: Unreported Length: 2 bytes Read Only</p> <p>4: Disabled Length: 2 bytes Read Write Value: 0x0000</p> <p>Description: The current alert status, unacknowledged states, unreported states, and disabled states of alarms associated with function block.</p>
ACK_OPTION	[Alarms]	38	<p>Length: 2 bytes Read Write Value: 0x0000</p>

			Description: Selection of whether alarms associated with the function block will be automatically acknowledged.
WRITE_PRI	[Options]	39	<p>Length: 1 bytes Read Write Value: 0</p> <p>Description: Priority of the alarm generated by clearing the write lock</p>
WRITE_ALM	[Others]	40	<p>1: Unacknowledged Length: 1 bytes Read Write</p> <p>2: Alarm State Length: 1 bytes Read Only</p> <p>3: Time Stamp Length: 8 bytes Read Only</p> <p>4: Sub Code Length: 2 bytes Read Only</p> <p>5: Value Length: 2 bytes Read Only</p> <p>Description: This alert is generated if the write lock parameter is cleared</p>
ITK_VER	[Others]	41	<p>Length: 2 bytes Read Only Value: 5</p> <p>Description: Major revision number of the interoperability test case used to register this device.</p>



## 6.2 Appendix - Transducer Block (MTB)

Transducer (MTB) Block			
Label / Name / Handling			Description / Format
ST_REV Static Revision  Read only	[Others]		Data format: Unsigned16 Value: 0  Description: The revision level of the static data associated with the function block. The revision value will be incremented each time a static parameter value in the block is changed.
TAG_DESC	[Process]		Description: The user description of the intended application of the block
STRATEGY	[Others]		Description: The strategy field can be used to identify grouping of blocks. That data is not checked or processed by the block.
ALERT_KEY	[Alarms]		Value: 0  Description: The identification number of the plant unit. This information may be used in the host for sorting alarms.
MODE_BLK	[Process] [Diagnostic]		1: Target 2: Actual 3: Permitted 4: Normal  Description: The actual target permitted and normal modes of the block
BLOCK_ERR	[Diagnostic]		Default value = 0x0000  Description: The parameter reflects the error status associated with the hardware or software components associated with a block. It's a bit string so that multiple errors can be shown
UPDATE_EVENT	[Others]		1: Unacknowledged 2: Update State 3: Time Stamp 4: Sub Code 5: Value  Description: This alert is generated by any changes to the static data
BLOCK_ALM	[Others]		1: Unacknowledged 2: Alarm State 3: Time Stamp

			4: Sub Code 5: Value  Description: The block alarm is used for all configuration hardware connected failure or system problems in the block. The cause of the alert is entered in the sub code field.
TRANSDUCER_TYPE	[I/O Cfg]		Description: Identifies the transducer that follows
XD_ERR	[Diagnostic]		Description: On of the transducer error code defined in the FF Transducer specifications
SENSOR_TYPE	[I/O Cfg]		Description: The type of sensor Value: NonStdSnsr
MEDIA	[Others]		Media Value: RS232 Description: Internal communication settings between Val Controls product and fieldbus interface. Do not change
BAUD_RATE	[Others]		Baud Rate Default Value:38400 Description: Internal communication settings between Val Controls product and fieldbus interface in Val Controls product. Do not change
STOP_BITS	[Others]		Stop Bits Value: One Stop Bit Description: Internal communication settings between Val Controls product and fieldbus interface. Do not change
PARITY	[Others]		Parity Value: Even Description: Internal communication settings between Val Controls product and fieldbus interface. Do not change
CRC_ORDER	[Others]		CRC Order Value: Normal Description: Internal communication settings between Val Controls product and fieldbus interface. Do not change
TIME_OUT	[Others]		Time Out Value: 300mSek Description: Internal communication settings between Val Controls product and fieldbus interface. Do not change
NUMBER_OF_RETRY	[Others]		Number of Retry Value: 5 Description: Internal communication settings between Val Controls product and fieldbus interface. Do not change
SLAVE_ADDRESS	[Others]		Slave Address

			Value: 1 Description: Internal communication settings between Val Controls product and fieldbus interface. Do not change
BAD_STATUS	[Others]		Bad Status Value: 0 Description: Error Look up table If a bit is high on of the MOD In/Out/D1/D1... If a input / output has bad status, the bit would be set here.
ERR_LOOK_SEL	[Others]		Err Look Select Value: The Error register to monitor. Only for status info
ERR_LOOK_RESULT	[Others]		Err Look Result Value: The status of the monitored register. Only for status info
MOD_IN1	[Others]		MOD_IN – Analog Input 1 Length: 4 bytes, Unsigned 16 Value: 0.00 – 100.00 Type: Position Value Value Status: Good, Bad .. Description: Analog Input from sensor
SCALE_LOC_IN1	[Others]		SCALE_LOC_IN Value FROM_EU100 = 10000 Value FROM_EU0 = 0 Value TO_EU100 = 100 Value TO_EU0 = 0 Value Data Type = Unsigned16_10 Value Function Code = FC03 Read Holding Register Value REGISTER_ADDR_OF_VALUE = 7000 Value REGISTER_ADDR_OF_STATUS = 7100  Description: Internal communication settings between Val Controls product and fieldbus interface. If input is not used set  REGISTER_ADDR_OF_STATUS = 0, Status sub status then changes to “Out of Service”
MOD_IN2	[Others]		MOD_IN Length: 4 bytes, Float Value: 0.00 – 100.00 Value Status: Good, Bad .. Description: Analog Input from sensor
SCALE_LOC_IN2	[Others]		SCALE_LOC_IN_2 Value FROM_EU100 = 10000

		Value FROM_EU0 = 0 Value TO_EU100 = 100 Value TO_EU0 = 0 Value Data Type = Unsigned16_10 Value Function Code = FC03 Read Holding Register Value REGISTER_ADDR_OF_VALUE = 7001 Value REGISTER_ADDR_OF_STATUS = 7101 Description: Internal communication settings between valcontrols product and fieldbus interface. If input is not used set REGISTER_ADDR_OF_STATUS = 0, Status sub status then changes to "Out of Service"
MOD_IN3	[Others]	MOD_IN Length: 4 bytes, Float Value: 0.00 – 100.00 Value Status: Good, Bad .. Description: Analog Input from sensor
SCALE_LOC_IN3	[Others]	SCALE_LOC_IN Value FROM_EU100 = 10000 Value FROM_EU0 = 0 Value TO_EU100 = 100 Value TO_EU0 = 0 Value Data Type = Unsigned16_10 Value Function Code = FC03 Read Holding Register Value REGISTER_ADDR_OF_VALUE = 7002 Value REGISTER_ADDR_OF_STATUS = 7102 Description: Internal communication settings between valcontrols product and fieldbus interface. If input is not used set REGISTER_ADDR_OF_STATUS = 0, Status sub status then changes to "Out of Service"
MOD_IN4	[Others]	MOD_IN Length: 4 bytes, Float Value: 0.00 – 100.00 Value Status: Good, Bad .. Description: Analog Input from sensor
SCALE_LOC_IN4	[Others]	SCALE_LOC_IN Value FROM_EU100 = 10000 Value FROM_EU0 = 0 Value TO_EU100 = 100 Value TO_EU0 = 0 Value Data Type = Unsigned16_10 Value Function Code = FC03 Read Holding Register Value REGISTER_ADDR_OF_VALUE = 7003 Value REGISTER_ADDR_OF_STATUS = 7103

			Description: Internal communication settings between val controls product and fieldbus interface. If input is not used set REGISTER_ADDR_OF_STATUS = 0, Status sub status then changes to “Out of Service”
MOD_IN5	[Others]		MOD_IN Length: 4 bytes, Float Value: 0.00 – 100.00 Value Status: Good, Bad .. Description: Analog Input from sensor
SCALE_LOC_IN5	[Others]		SCALE_LOC_IN Value FROM_EU100 = 10000 Value FROM_EU0 = 0 Value TO_EU100 = 100 Value TO_EU0 = 0 Value Data Type = Unsigned16_10 Value Function Code = FC03 Read Holding Register Value REGISTER_ADDR_OF_VALUE = 7004 Value REGISTER_ADDR_OF_STATUS = 7104 Description: Internal communication settings between valcontrols product and fieldbus interface. If input is not used set REGISTER_ADDR_OF_STATUS = 0, Status sub status then changes to “Out of Service”
MOD_IN6	[Others]		MOD_IN Length: 4 bytes, Float Value: 0.00 – 100.00 Value Status: Good, Bad .. Description: Analog Input from sensor
SCALE_LOC_IN6	[Others]		SCALE_LOC_IN_6 Value FROM_EU100 = 10000 Value FROM_EU0 = 0 Value TO_EU100 = 100 Value TO_EU0 = 0 Value Data Type = Unsigned16_10 Value Function Code = FC03 Read Holding Register Value REGISTER_ADDR_OF_VALUE = 7005 Value REGISTER_ADDR_OF_STATUS = 7105 Description: Internal communication settings between valcontrols product and fieldbus interface. If input is not used set REGISTER_ADDR_OF_STATUS = 0, Status sub status then changes to “Out of Service”
MOD_IN7	[Others]		MOD_IN Length: 4 bytes, Float Value: 0.00 – 100.00

			Value Status: Good, Bad .. Description: Analog Input from sensor
SCALE_LOC_IN7	[Others]		SCALE_LOC_IN_7 Value FROM_EU100 = 10000 Value FROM_EU0 = 0 Value TO_EU100 = 100 Value TO_EU0 = 0 Value Data Type = Unsigned16_10 Value Function Code = FC03 Read Holding Register Value REGISTER_ADDR_OF_VALUE = 7006 Value REGISTER_ADDR_OF_STATUS = 7106 Description: Internal communication settings between valcontrols product and fieldbus interface. If input is not used set REGISTER_ADDR_OF_STATUS = 0, Status sub status then changes to “Out of Service”
MOD_IN8	[Others]		MOD_IN Length: 4 bytes, Float Value: 0.00 – 100.00 Value Status: Good, Bad .. Description: Analog Input from sensor
SCALE_LOC_IN8	[Others]		SCALE_LOC_IN_8 Value FROM_EU100 = 10000 Value FROM_EU0 = 0 Value TO_EU100 = 100 Value TO_EU0 = 0 Value Data Type = Unsigned16_10 Value Function Code = FC03 Read Holding Register Value REGISTER_ADDR_OF_VALUE = 7007 Value REGISTER_ADDR_OF_STATUS = 7107 Description: Internal communication settings between valcontrols product and fieldbus interface. If input is not used set REGISTER_ADDR_OF_STATUS = 0, Status sub status then changes to “Out of Service”
MOD_OUT1	[Others]		MOD_OUT Value: 0.00 – 100.00 Value Status: Good, Bad ..  Value is received from AO via channel 1  Description: Analog control value such as SP that need to be send to the Val Controls Device
SCALE_LOC_OUT1	[Others]		SCALE_LOC_OUT1 Value FROM_EU100 = 100 Value FROM_EU0 = 0

			Value TO_EU100 = 10000 Value TO_EU0 = 0 Value Data Type = Unsigned16_10 Value Function Code = FC16 Write Multiple Register Value REGISTER_ADDR_OF_VALUE = 7010 Value REGISTER_ADDR_OF_STATUS = 7110  Description: Internal communication settings between valcontrols product and fieldbus interface. Value and status send from Fieldbus function and send down into Val Controls Unit. Value can also be scaled.
MOD_OUT2	[Others]		Same as MOD_OUT1
SCALE_LOC_OUT2	[Others]		Same as SCALE_LOC_OUT1 Value REGISTER_ADDR_OF_VALUE = 7011 Value REGISTER_ADDR_OF_STATUS = 7111
MOD_OUT3	[Others]		Same as MOD_OUT1
SCALE_LOC_OUT3	[Others]		Same as SCALE_LOC_OUT1 Value REGISTER_ADDR_OF_VALUE = 7012 Value REGISTER_ADDR_OF_STATUS = 7112
MOD_OUT4	[Others]		Same as MOD_OUT1
SCALE_LOC_OUT4	[Others]		Same as SCALE_LOC_OUT1 Value REGISTER_ADDR_OF_VALUE = 7013 Value REGISTER_ADDR_OF_STATUS = 7113
MOD_OUT5	[Others]		Same as MOD_OUT1
SCALE_LOC_OUT5	[Others]		Same as SCALE_LOC_OUT1 Value REGISTER_ADDR_OF_VALUE = 7014 Value REGISTER_ADDR_OF_STATUS = 7114
MOD_OUT6	[Others]		Same as MOD_OUT1
SCALE_LOC_OUT6	[Others]		Same as SCALE_LOC_OUT1 Value REGISTER_ADDR_OF_VALUE = 7015 Value REGISTER_ADDR_OF_STATUS = 7115
MOD_OUT7	[Others]		Same as MOD_OUT1
SCALE_LOC_OUT7	[Others]		Same as SCALE_LOC_OUT1 Value REGISTER_ADDR_OF_VALUE = 7016 Value REGISTER_ADDR_OF_STATUS = 7116
MOD_OUT8	[Others]		Same as MOD_OUT1
SCALE_LOC_OUT8	[Others]		Same as SCALE_LOC_OUT1 Value REGISTER_ADDR_OF_VALUE = 7017 Value REGISTER_ADDR_OF_STATUS = 7117
MOD_IN_D1	[Others]		MOD_IN_D1 Length: 1 bytes 1: Value: 0 to 255 Read from Sensor 2: Status - Quality: Good, Bad ..



			Status – Sub status: Non Specific .. Status – Limits: Not Limited  Description: Discrete Input from sensor in valcontrols product
LOC_IN_D1	[Others]		LOC_IN_D1 Value Data Type = Unsigned8_0 Value Function Code = FC03 Reading Holding Register Value REGISTER_ADDR_OF_VALUE = 7020 Value REGISTER_ADDR_OF_STATUS = 7120  Description: Internal communication settings between valcontrols product and fieldbus interface. If input is not used set REGISTER_ADDR_OF_STATUS = 0, Status sub status then changes to “Out of Service”
MOD_IN_D2	[Others]		Same as MOD_IN_D1
LOC_IN_D2	[Others]		Same as LOC_IN_D1 Value REGISTER_ADDR_OF_VALUE = 7021 Value REGISTER_ADDR_OF_STATUS = 7121
MOD_IN_D3	[Others]		Same as MOD_IN_D1
LOC_IN_D3	[Others]		Same as LOC_IN_D1 Value REGISTER_ADDR_OF_VALUE = 7022 Value REGISTER_ADDR_OF_STATUS = 7122
MOD_IN_D4	[Others]		Same as MOD_IN_D1
LOC_IN_D4	[Others]		Same as LOC_IN_D1 Value REGISTER_ADDR_OF_VALUE = 7023 Value REGISTER_ADDR_OF_STATUS = 7123
MOD_IN_D5	[Others]		Same as MOD_IN_D1
LOC_IN_D5	[Others]		Same as LOC_IN_D1 Value REGISTER_ADDR_OF_VALUE = 7024 Value REGISTER_ADDR_OF_STATUS = 7124
MOD_IN_D6	[Others]		Same as MOD_IN_D1
LOC_IN_D6	[Others]		Same as LOC_IN_D1 Value REGISTER_ADDR_OF_VALUE = 7025 Value REGISTER_ADDR_OF_STATUS = 7125
MOD_IN_D7	[Others]		Same as MOD_IN_D1
LOC_IN_D7	[Others]		Same as LOC_IN_D1 Value REGISTER_ADDR_OF_VALUE = 7026 Value REGISTER_ADDR_OF_STATUS = 7126
MOD_IN_D8	[Others]		Same as MOD_IN_D1
LOC_IN_D8	[Others]		Same as LOC_IN_D1 Value REGISTER_ADDR_OF_VALUE = 7027 Value REGISTER_ADDR_OF_STATUS = 7028
MOD_OUT_D1	[Others]		MOD_OUT_D1 Value: State 0 .. 255 Value Status: Good, Bad ..



			Description: Discrete output from Fieldbus to Val Controls product Can be used as an external switch, or something.
LOC_OUT_D1	[Others]		LOC_OUT_D1 Value Function Code = FC05 Write Single Register Value REGISTER_ADDR_OF_VALUE = 7030 Value REGISTER_ADDR_OF_STATUS = 7130
MOD_OUT_D2	[Others]		Same as LOC_IN_D1
LOC_OUT_D2	[Others]		Same as LOC_OUT_D1 Value REGISTER_ADDR_OF_VALUE = 7031 Value REGISTER_ADDR_OF_STATUS = 7131
MOD_OUT_D3	[Others]		Same as LOC_OUT_D1
LOC_OUT_D3	[Others]		Same as LOC_OUT_D1 Value REGISTER_ADDR_OF_VALUE = 7032 Value REGISTER_ADDR_OF_STATUS = 7132
MOD_OUT_D4	[Others]		Same as LOC_OUT_D1
LOC_OUT_D4	[Others]		Same as LOC_OUT_D1 Value REGISTER_ADDR_OF_VALUE = 7033 Value REGISTER_ADDR_OF_STATUS = 7033
MOD_OUT_D5	[Others]		Same as LOC_OUT_D1
LOC_OUT_D5	[Others]		Same as LOC_OUT_D1 Value REGISTER_ADDR_OF_VALUE = 7034 Value REGISTER_ADDR_OF_STATUS = 7034
MOD_OUT_D6	[Others]		Same as LOC_OUT_D1
LOC_OUT_D6	[Others]		Same as LOC_OUT_D1 Value REGISTER_ADDR_OF_VALUE = 7035 Value REGISTER_ADDR_OF_STATUS = 7035
MOD_OUT_D7	[Others]		Same as LOC_OUT_D1
LOC_OUT_D7	[Others]		Same as LOC_OUT_D1 Value REGISTER_ADDR_OF_VALUE = 7036 Value REGISTER_ADDR_OF_STATUS = 7036
MOD_OUT_D8	[Others]		Same as LOC_OUT_D1
LOC_OUT_D8	[Others]		Same as LOC_OUT_D1 Value REGISTER_ADDR_OF_VALUE = 7037 Value REGISTER_ADDR_OF_STATUS = 7037

### 6.3 Appendix - Analogue Input Function Block (AI)

Analogue Input Function (AI) Block			
Label / Name / Handling		Idx rel.	Description / Format
		0	
ST_REV	[Others]	1	Length 2 byte Read Only  Description: The revision level of the Static data associated with the Function Block. The revision level is incremented each time a static parameter value in the block is changed.
TAG_DESC	[Process]	2	Length 32 byte Read Write  Description: The user description of the intended application of the block
STRATEGY	[Others]	3	Length 2 byte Read Write  Description: The strategy field can be used to identify grouping of blocks. This data is not checked or processed by the block.
ALERT_KEY	[Alarm]	4	Length 1 byte Read Write  Description: The identification number of the plant unit. This information may be used in the host for sorting alarms, etc.
MODE_BLK	[Process] [Diagnostic]	5	1: Target Length 1 byte Read Write The selected mode from the operator.  2: Actual Length 1 byte Read Only The mode the block is currently in.  3: Permitted Length 1 byte Read Write Allowed modes that the target may take on  4: Normal

			Length 1 byte Read Write  Description: The common mode for the Actual target
BLOCK_ERR	[Diagnostic]	6	Length 2 byte Read Only  Description: This parameter reflects the error status associated with the hardware or software components associated with a block. It is a bit string, so that multiple errors may be shown.
PV	[Process] [Trends]	7	1: Process Variable Length 4 byte Read Only  Description: The process variable read from the hardware, addressed in the Modbus Transducer block  2: Process Variable Status Length 1 byte Read Only The process variable status
OUT	[Process]	8	Length 4 byte Read Only  Description: The block output value calculated as a result of the block execution.
SIMULATE	[Options]	9	1: Simulate Status Length 1 byte Read Write  2: Simulate Value Length 4 byte Read Write  3: Current Transducer Status Length 1 byte Read Only  4: Current Transducer Value Length 4 byte Read Write  5: Simulation Enable/Disable bit Length 1 byte Read Write  Description: Allows the transducer analog input or

			output to the block to be manually supplied when simulate is enabled. When simulate is disabled the simulate value and status track the actual value and status.
XD_SCALE	[Scaling]	10	<p>1: High Range All the values are associated with the EU_100          Length 4 byte          Read Write          Value: 100</p> <p>2: EU_0          Length 4 byte          Read Write          Value: 0</p> <p>3: Unit Index          Length 2 byte          Read Write          Value: %</p> <p>4: Decimal point          Length 1 byte          Read Write          Value: 2</p> <p>Description: The EU_100 high and EU_0 low scale values engineering unit code, and number of digits to the right of the decimal point used with the value obtained from the transducer for a specific channel.</p>
OUT_SCALE	[Scaling]	11	<p>1: EU_100 High Range          Length 4 byte          Read Write          Value: 100</p> <p>2: EU_0 Low Range          Length 4 byte          Read Write          Value: 0</p> <p>3: Unit Index          Length 2 byte          Read Write          Value %</p> <p>4: Decimal Point          Length 1 byte          Read Write          Value: 2</p>

			Description: The high and low values engineering units code and number of digits of the right of the decimal point to be used in displaying the OUT parameter and parameters which have the same scale out.
GRANT_DENY	[Options]	12	<p>1: Grant Length 1 byte Read Write Value: 0</p> <p>2: Deny Length 1 byte Read Write Value: 0</p> <p>Program Denied – Granting of program permission has been reset Tune Denied – Granting of tune permission has been reset Alarm Denied – Granting of alarm permission has been reset Local – Granting of local permission has been reset</p> <p>Description: Options for controlling access of host computers and local control panes to operating tuning and alarm parameters of the block.</p>
IO_OPTS	[Options]	13	<p>Length 2 byte Read Write Value 0x0000</p> <p>Description: Option which the user can select to alter Input and Output block processing Only the Low cutoff can be enabled/disabled</p>
STATUS_OPTS	[Options]	14	<p>Length 2 byte Read Write Value 0x0000</p> <p>Description: Option which the user can select block processing of status.</p>
CHANNEL	[Process]	15	<p>Length 2 byte Read Write</p> <p>Description: The channel to get the value to the Block from.</p>
L_TYPE	[Scaling]	16	<p>Length 1 byte Read Write</p>

			<p>Value: uninitialized</p> <p>Description: Determines if the values passed by the transducer block to the AI block may be used directly “Direct” or if the value is in different units and must be converted linearly “Indirect” or with square root “Ind Sqr Root” using input range defined for the transducer block.</p>
LOW_CUT	[Tuning]	17	<p>Length 4 byte Read Write Value: 0</p> <p>Description: Limit used in square root processing. A value of zero percent of scale is used in block processing if the transducer value fails below this limit in % of scale: This feature may be used to eliminate noise near zero from a flow sensor.</p>
PV_FTIME	[Tuning]	18	<p>Length 4 byte Read Write Value: 0 sec</p> <p>Description: Time constant of a single exponential filter for the PV in seconds</p>
FIELD_VAL	[Process] [Trends]	19	<p>1: Value Length 4 byte Read Only Value: 0</p> <p>2: Status Length 1 byte Read Only</p> <p>Description: Raw value of the field device in % of PV range.</p>
UPDATE_EVT	[Others]	20	<p>1 Unacknowledged: Length: 1 bytes Read Write</p> <p>2 Update State: Length: 1 bytes Read Only</p> <p>3 Time Stamp: Length: 8 bytes Read Only</p>

			<p>4 Static Revision: Length: 2 bytes Read Only</p> <p>Relative Index: Length: 2 bytes Read Only</p> <p>Description: This alert is generated by any change to the static data.</p>
BLOCK_ALM	[Others]	21	<p>1: Unacknowledged Length: 1 bytes Read Write</p> <p>2: Alarm State Length: 1 bytes Read Only</p> <p>3: Time Stamp Length: 8 bytes Read Only</p> <p>4: Subcode Length: 2 bytes Read Only</p> <p>5: Value Length: 1 bytes Read Only</p> <p>Description: The block alarm is used for all configuration hardware connected failure or system problems in the block. The cause of the alert is entered in the sub code field.</p>
ALARM_SUM	[Others]	22	<p>1: Current Length: 2 bytes Read Only</p> <p>2: Unacknowledged Length: 2 bytes Read Only</p> <p>3: Unreported Length: 2 bytes Read Only</p>

			4: Disabled Length: 2 bytes Read Write Value: 0x0000  Description: The current alert status, unacknowledged states, unreported states, and disabled states of alarms associated with function block.
ACK_OPTION	[Alarm]	23	Length 2 bytes Read Write  Description: Selection of whether alarms associated with the function block will be automatically acknowledged.
ALARM_HYS	[Alarm]	24	Length 4 bytes Read Write Value: 0.5%  Range: 0-50%  Description: Amount the PV must return with the alarm limits before the alarm condition clears. Alarm hysteresis as a percent of the span of the PV
HI_HI_PRI	[Alarm]	25	Length 1 byte Read Write Value: 0  Description: Priority of the High high alarm
HI_HI_LIM	[Alarm]	26	Length 4 bytes Read Write Value: 1. #INF  Description: The setting for high high alarm in engineering units
HI_PRI	[Alarm]	27	Length 1 byte Read Write Value: 0  Description: Priority of the high alarm
HI_LIM	[Alarm]	28	Length 4 bytes Read Write Value: 1 #INF  Description: The setting for high alarm in engineering units



LO_PRI	[Alarm]	29	Length 1 byte Read Write Value: 0  Description: Priority of the low alarm
LO_LIM	[Alarm]	30	Length 4 bytes Read Write Value 1 #INF  Description: The setting for low alarm in engineering units
LO_LO_PRI	[Alarm]	31	Length 1 byte Read Write  Value: 0  Description: Priority of the low low alarm
LO_LO_LIM	[Alarm]	32	Length 4 bytes Read Write  Value: -1. #INF  Description: The setting for low low alarm in engineering units
HI_HI_ALM	[Others]	33	1: Unacknowledged Length 1 byte Read Write  2: Alarm state Length 1 byte Read Only  3: Time stamp Length 8 bytes Read Only  4: Sub code Length 2 bytes Read Only  5: Value Length 4 bytes Read Only  Description: The status for high high alarm and its associated time stamp.
HI_ALM	[Others]	34	1: Unacknowledged Length 1 byte

			<p>Read Write</p> <p>2: Alarm state Length 1 byte Read Only</p> <p>3: Time stamp Length 8 bytes Read Only</p> <p>4: Sub code Length 2 bytes Read Only</p> <p>5: Value Length 4 bytes Read Only</p> <p>Description: The status for high alarm and its associated time stamp.</p>
LO_ALM	[Others]	35	<p>1: Unacknowledged Length 1 byte Read Write</p> <p>2: Alarm state Length 1 byte Read Only</p> <p>3: Time stamp Length 8 bytes Read Only</p> <p>4: Sub code Length 2 bytes Read Only</p> <p>5: Value Length 4 bytes Read Only</p> <p>Description: The status for low alarm and its associated time stamp.</p>
LO_LO_ALM	[Others]	36	<p>1: Unacknowledged Length 1 byte Read Write</p> <p>2: Alarm state Length 1 byte</p>

		<p>Read Only</p> <p>3: Time stamp        Length 8 bytes        Read Only</p> <p>4: Sub code        Length 2 bytes        Read Only</p> <p>5: Value        Length 4 bytes        Read Only</p> <p>Description: The status for low low alarm and its associated time stamp.</p>
--	--	---

## 6.4 Appendix - Analogue Output Function Block (AO)

Analogue Input Function (AO) Block			
Label / Name / Handling			Description / Format
ST_REV	[Others]		<p>Length 2 byte Read Only</p> <p>Description: The revision level of the Static data associated with the Function Block. The revision level is incremented each time a static parameter value in the block is changed.</p>
TAG_DESC	[Process]		<p>Length 32 byte Read Write</p> <p>Description: The user description of the intended application of the block</p>
STRATEGY	[Others]		<p>Length 2 byte Read Write</p> <p>Description: The strategy field can be used to identify grouping of blocks. This data is not checked or processed by the block.</p>
ALERT_KEY	[Alarm]		<p>Length 1 byte Read Write</p> <p>Default 1</p> <p>Description: The identification number of the plant unit. This information may be used in the host for sorting alarms, etc.</p>
MODE_BLK	[Process] [Diagnostic]		<p>1: Target Length 1 byte Read Write The selected mode from the operator.</p> <p>2: Actual Length 1 byte Read Only The mode the block is currently in.</p> <p>3: Permitted Length 1 byte Read Write Allowed modes that the target may take on</p>

			4: Normal Length 1 byte Read Write  Description: The common mode for the Actual target
BLOCK_ERR	[Diagnostic]		Length 2 byte Read Only  Description: This parameter reflects the error status associated with the hardware or software components associated with a block. It is a bit string, so that multiple errors may be shown.
PV	[Process] [Trends]		1: Process Variable Length 4 byte Read Only  Description: The process variable read from the hardware, addressed in the Modbus Transducer block  2: Process Variable Status Length 1 byte Read Only The process variable status
SP	[Process]		1: Value 2: Status Length 1 byte Read Write The set point variable status  Description: The analog set point of this block.
OUT	[Process]		Length 4 byte Read Only  Description: The block output value calculated as a result of the block execution.
CAS_IN	[Process]		1: Value 2: Status Length 1 byte Write The set point variable status  Description: This parameter is the remote setpoint value which must come from another Fieldbus block, or a DCS block through a defined link.
BKCAL_OUT	[Process]		1: Value 2: Status Length 1 byte

			<p>Read Only The set point variable status</p> <p>Description: The output value and status provided to an upstream block for output tracking when the loop is broken or limited, as determined by the status bits. This information is used to provide bump less transfer to closed loop control and to prevent windup under limited conditions when that becomes possible</p>
RCAS_IN	[Process]		<p>1: Value 2: Status Length 1 byte Write The set point variable status</p> <p>Description: Target set point and status provided by a supervisor Host to a analog control or output block</p>
RCAS_OUT	[Process]		<p>1: Value 2: Status Length 1 byte Read Only The set point variable status</p> <p>Description: Block set point and status after ramping – provided to a supervisory Host for back calculation and to allow action to be taken under limiting conditions or made change.</p>
SIMULATE	[Options]		<p>1: Simulate Status Length 1 byte Read Write</p> <p>2: Simulate Value Length 4 byte Read Write</p> <p>3: Current Transducer Status Length 1 byte Read Only</p> <p>4: Current Transducer Value Length 4 byte Read Write</p> <p>5: Simulation Enable/Disable bit Length 1 byte Read Write</p> <p>Description: Allows the transducer analog input or</p>

		output to the block to be manually supplied when simulate is enabled. When simulate is disabled the simulate value and status track the actual value and status.
XD_SCALE	[Scaling]	<p>1: High Range All the values are associated with the EU_100          Length 4 byte          Read Write          Value: 100</p> <p>2: EU_0          Length 4 byte          Read Write          Value: 0</p> <p>3: Unit Index          Length 2 byte          Read Write          Value: %</p> <p>4: Decimal point          Length 1 byte          Read Write          Value: 2</p> <p>Description: The EU_100 high and EU_0 low scale values engineering unit code, and number of digits to the right of the decimal point used with the value obtained from the transducer for a specific channel.</p>
GRANT_DENY	[Options]	<p>1: Grant          Length 1 byte          Read Write          Value: 0</p> <p>2: Deny          Length 1 byte          Read Write          Value: 0</p> <p>Program Denied – Granting of program permission has been reset          Tune Denied – Granting of tune permission has been reset          Alarm Denied – Granting of alarm permission has been reset          Local – Granting of local permission has been reset</p>

			Description: Options for controlling access of host computers and local control panes to operating tuning and alarm parameters of the block.
IO_OPTS	[Options]		Length 2 byte Read Write Value 0x0000  Description: Option which the user can select to alter Input and Output block processing Only the Low cutoff can be enabled/disabled
STATUS_OPTS	[Options]		Length 2 byte Read Write Value 0x0000  Description: Option which the user can select block processing of status.
CHANNEL	[Process]		Length 2 byte Read Write  Description: The CHANNEL 1 to 8
FIELD_VAL	[Process] [Trends]		1: Value Length 4 byte Read Only Value: 0  2: Status Length 1 byte Read Only  Description: Raw value of the field device in % of PV range.
UPDATE_EVT	[Others]		1 Unacknowledged: Length: 1 bytes Read Write  2 Update State: Length: 1 bytes Read Only  3 Time Stamp: Length: 8 bytes Read Only  4 Static Revision: Length: 2 bytes



			<p>Read Only</p> <p>Relative Index: Length: 2 bytes Read Only</p> <p>Description: This alert is generated by any change to the static data.</p>
BLOCK_ALM	[Others]		<p>1: Unacknowledged Length: 1 bytes Read Write</p> <p>2: Alarm State Length: 1 bytes Read Only</p> <p>3: Time Stamp Length: 8 bytes Read Only</p> <p>4: Sub code Length: 2 bytes Read Only</p> <p>5: Value Length: 1 bytes Read Only</p> <p>Description: The block alarm is used for all configuration hardware connected failure or system problems in the block. The cause of the alert is entered in the sub code field.</p>
FSTATE_TIME	[Options]		<p>Description: The time in seconds from detection of failure of the output block remote set point to the output action of the block if the condition still exists.</p>
FSTATE_VAL	[Options]		<p>Description: The preset analog SP value to use when failure occurs. This value will be used if the I/O option fault state to value is selected.</p>
SHED_OPT	[Options]		<p>Description: Defines action to be taken on remote control device timeout.</p>
PV_SCALE	[Scaling]		<p>Description: The high and low scale values. Engineering units code and number of digits to the right of decimal point to be used in displaying the PV parameter and parameters which have the same scaling as PV</p>
SP_RATE_ON	[Limits]		<p>Description: Ramp rate at which downward set point changes are acted on in Auto mode. In PV units per second. If the ramp rate is set to zero or the block is</p>

			in a mode other than Auto then the set point will be used immediately.
SP_RATE_UP	[Limits]		Description: Ramp rate at which upward set point changes are acted on in Auto mode. In PV units per second. If the ramp rate is set to zero or the block is in a mode other than Auto then the set point will be used immediately.
SP_HI_LIM	[Limits]		Description: The set point high limit is the highest set point operator entry that can be used for the block
SP_LO_LIM	[Limits]		Description: The set point low limit is the lowest set point operator entry that can be used for the block
READBACK	[Tuning]		Description: This indicates the read back of the actual continuous value or other actuator position in transducer units.

## 6.5 Appendix - Discrete Input Function Block (DI)

Digital Input Function (DI) Block			
Label / Name / Handling			Description / Format
ST_REV	[Others]		Length 2 byte Read Only  Description: The revision level of the Static data associated with the Function Block. The revision level is incremented each time a static parameter value in the block is changed.
TAG_DESC	[Process]		Length 32 byte Read Write  Description: The user description of the intended application of the block
MODE_BLK	[Process] [Diagnostic]		Description: The mode record of the block. Contains the actual, target, permitted, and normal modes
PV_D	[Process]		Description: The discrete process variable used in block execution.
OUT_D	[Process]		Description: The discrete output value and status
XD_STATE	[Process]		Description: Index to the text describing the states of a discrete for the value obtained from the transducer.
OUT_STATE	[Process]		Description: Index to the text describing the states of a discrete output.
CHANNEL	[Process]		Description: Defines the I/O input used for the field measurement
FIELD_VAL_D	[Process]		Description: The value and status of the discrete input from a field device
PV_FTIME	[Tuning]		Description: The constant of a single exponential filter for the PV, in seconds.
SIMULATE_D	[Options]		Description: Enables simulation and allows you to enter an input value and status when SIMULATE_IN_D is not connected.
GRANT_DENY	[Options]		Description: Options for controlling access of host computers and local control panels to opening, tuning and alarm parameters of the block.
IO_OPTS	[Options]		Description: Allows you to select options for I/O value processing.  The supported I/O option  “Fault State to Value” – If a fault occurs, the SP

			changes to FSTATE_VAL value.
STATUS_OPTS	[Options]		Description: Options which the user may select in the block processing of status.
ALERT_KEY	[Alarms]		Description: The identification number of the plant unit. This information may be used in the host for sorting alarms etc.
ACK_OPTION	[Alarms]		Description: Selection of whether alarms associated with the function block will be automatically acknowledged.
DISC_PRI	[Alarms]		Description: Priority of the Discrete alarm
DISC_LIM	[Alarms]		Description: The state of the discrete input that causes an alarm. Any number from 0 to 255 may be. State 255 specifies that no alarm indication is to be shown
BLOCK_ERR	[Diagnostic]		Description: The summary of active error conditions associated with the block. The supported block errors in the Discrete Input function block are Simulate active, Input failure/process variable has Bad status, and Out of service.
STRATEGY	[Others]		Description: The strategy field can be used to identify grouping of blocks. This data is not checked or processed by the block.
UPDATE_EVT	[Others]		<p>1 Unacknowledged: Length: 1 bytes Read Write</p> <p>2 Update State: Length: 1 bytes Read Only</p> <p>3 Time Stamp: Length: 8 bytes Read Only</p> <p>4 Static Revision: Length: 2 bytes Read Only</p> <p>Relative Index: Length: 2 bytes Read Only</p> <p>Description: This alert is generated by any change to</p>

			the static data.
BLOCK_ALM	[Others]		<p>1: Unacknowledged Length: 1 bytes Read Write</p> <p>2: Alarm State Length: 1 bytes Read Only</p> <p>3: Time Stamp Length: 8 bytes Read Only</p> <p>4: Sub code Length: 2 bytes Read Only</p> <p>5: Value Length: 1 bytes Read Only</p> <p>Description: The block alarm is used for all configuration hardware connected failure or system problems in the block. The cause of the alert is entered in the sub code field.</p>
ALARM_SUM	[Others]		Description: The current alert status unacknowledged states, unreported states, and disabled states of the alarms associated with the function block.
DISC_ALM	[Others]		Description: The status and time stamp associated with the discrete alarm

## 6.6 Appendix - Discrete Output Function Block (DO)

Digital Output Function (DO) Block			
Label / Name / Handling		Idx rel.	Description / Format
ST_REV	[Others]		<p>Length 2 byte Read Only</p> <p>Description: The revision level of the Static data associated with the Function Block. The revision level is incremented each time a static parameter value in the block is changed.</p>
TAG_DESC	[Process]		Length 32 byte

			Read Write  Description: The user description of the intended application of the block
MODE_BLK	[Process] [Diagnostic]		Description: The actual target, permitted, and normal modes of the block.
PV_D	[Process]		Description: Either the primary discrete value for use in executing the function or a process value associated with it. May also be calculated from the READBACK_D value of a DO block.
SP_D	[Process]		Description: The discrete set point of this block.
OUT_D	[Process]		Description: The primary discrete value calculated as a result of executing the function block.
XD_STATE	[Process]		Description: Index to the text describing the states of a discrete for the value obtained from the transducer.
CAS_IN_D	[Process]		Description: This parameter is the remote set point value of a discrete block, which must come from another Fieldbus block, or a DCS block through a defined link.
CHANNEL	[Process]		Description: The number of logical hardware channel that is connected to this I/O block. This information defines the transducer to be used going to or from the physical unit.
RCAS_IN_D	[Process]		Description: Target set point and status provided by a supervisory Host to a discrete control or output block.
RCAS_OUT_D	[Process]		Description: Block set point and status provided to a supervisory Host for back calculation and to allow action to be taken under limiting conditions or mode change.
READBACK_D	[Tuning]		Description: This indicates the read back of the actual discrete valve or other actuator position, in the transducer state.
SIMULATE_D	[Options]		Description: Allows the transducer discrete input or output to the block to be manually supplied when simulate is enabled. When simulation is disabled, the simulate value and status track the actual value and status.
GRANT_DENY	[Options]		Description: Options for controlling access of host computer and local control panels to operating, tuning and alarm parameters of the block.
IO_OPTS	[Options]		Description: Options which the user may select to alter input and output block processing.
STATUS_OPTS	[Options]		Description: Options which the user may select in the block processing of status.
FSTATE_TIME	[Options]		Description: The time in seconds from detection of fault of the output block remote set point to the output action of the block output if the condition still

			exists.
FSTATE_VAL_D	[Options]		Description: The preset discrete SP_D value to use when fault occurs. This value will be used if the I/O option Fault State to value is selected.
SHED_OPT	[Options]		Description: Defines action to be taken on remote control device timeout.
ALERT_KEY	[Alarms]		Description: The identification number of the plant unit. This information may be used in the host for sorting alarms etc.
BLOCK_ERR	[Diagnostic]		Description: This parameter reflects the error status associated with the hardware or software components associated with a block. It is a bit string, so that multiple errors may be shown.
STRATEGY	[Others]		Description: The strategy field can be used to identify grouping of blocks. This data is not checked or processed by the block.
PV_STATE	[Others]		Description: Index to the text describing the states of a discrete PV.
BKCAL_OUT_D	[Others]		Description: The output value and status provided to an upstream discrete block. This information is used to provide bump less transfer to closed loop control.
UPDATE_EVT	[Others]		Description: This alert is generated by any change to the static data.
BLOCK_ALM	[Others]		Description: The block alarm is used for all configuration, hardware, and connection failure or system problems in the block. The cause of the alert is entered in the sub-code field. The first alert to become active will set the Active status in the Status attribute. As soon as the Unreported status is cleared by the alert reporting task, another block alert may be reported without clearing the Active status, if the sub-code has changed.

## 6.7 Appendix - PID Function Block (PID)

Follows the standard for Fieldbus PID functionality.

## 7 Trouble Guide

### 7.1 Check “Err Lock Result”

Internally in IHP24 there is a hardware foundation fieldbus module. This module communicates with the rest of the hardware in IHP24 via a local modbus interface. This interface needs to run at a fixed setup.

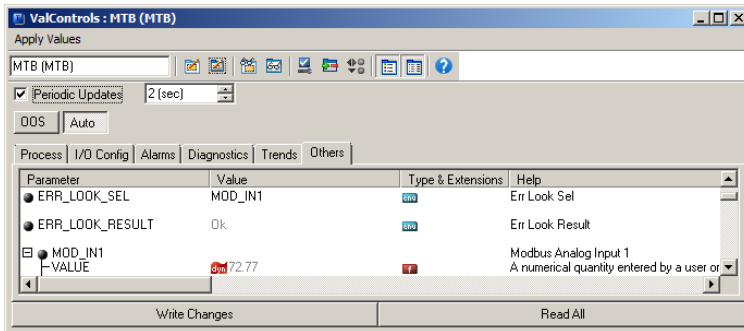

If the “ERR\_LOCK\_RESULT” parameter is not “Ok” .. but “COMM Err”

On the IHP24 enter the setup menu.

In the Local Display Menu System on the IHP24 go to “Setup Menu”

2. Advanced → 6.Modbus → 2.Baudrate

- Select 38400 baud

2. Advanced → 6.Modbus → 1.ID

- Select 1

2. Advanced → 6.Modbus → 3.Parity

- Select Even

2. Advanced → 6.Modbus → 4.Stopbits

- Select 1

Remember to save when you leave the menu system.



## 8 Important Issues

### 8.1 Limitation in use of Factory Reset in NI-FBUS

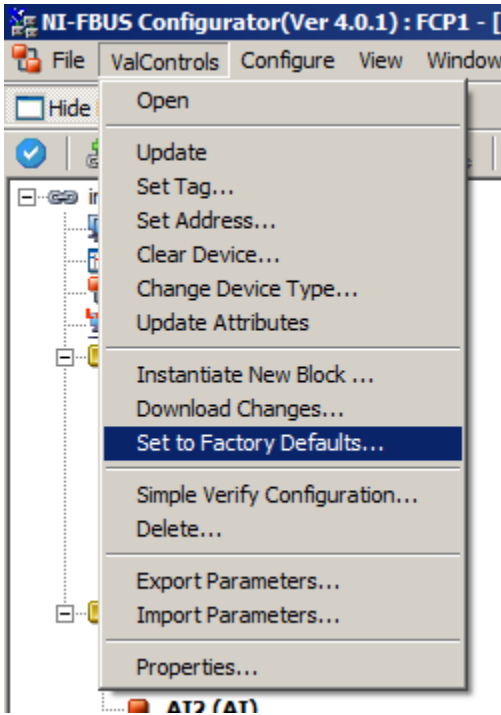

- Don't use the "Set to Factory Defaults..". This will reset all "Tag names" and clear all values in the MTB transducerblock. The device will not be able to communicate anymore.
- Don't use the "Set to Factory Defaults.." function when unit its running on a HSE network. This will cause the Fieldbus Device in a locked state.

### 8.2 Always upload configuration before configuration

- Upload the configuration from the device before you modify the configuration of the device and afterwards downloading the new configuration.

### 8.3 Don't remove power when updating configuration

- Don't remove the power when downloading a new configuration to the device.

### 8.4 Don't use the MTB Transducer block, in Function block Application

Don't use the MTB block in the Function block Application.

If the configuration is downloaded to device this will destroy the configuration and parameters set in the device, so that it can't connect to the fieldbus anymore.

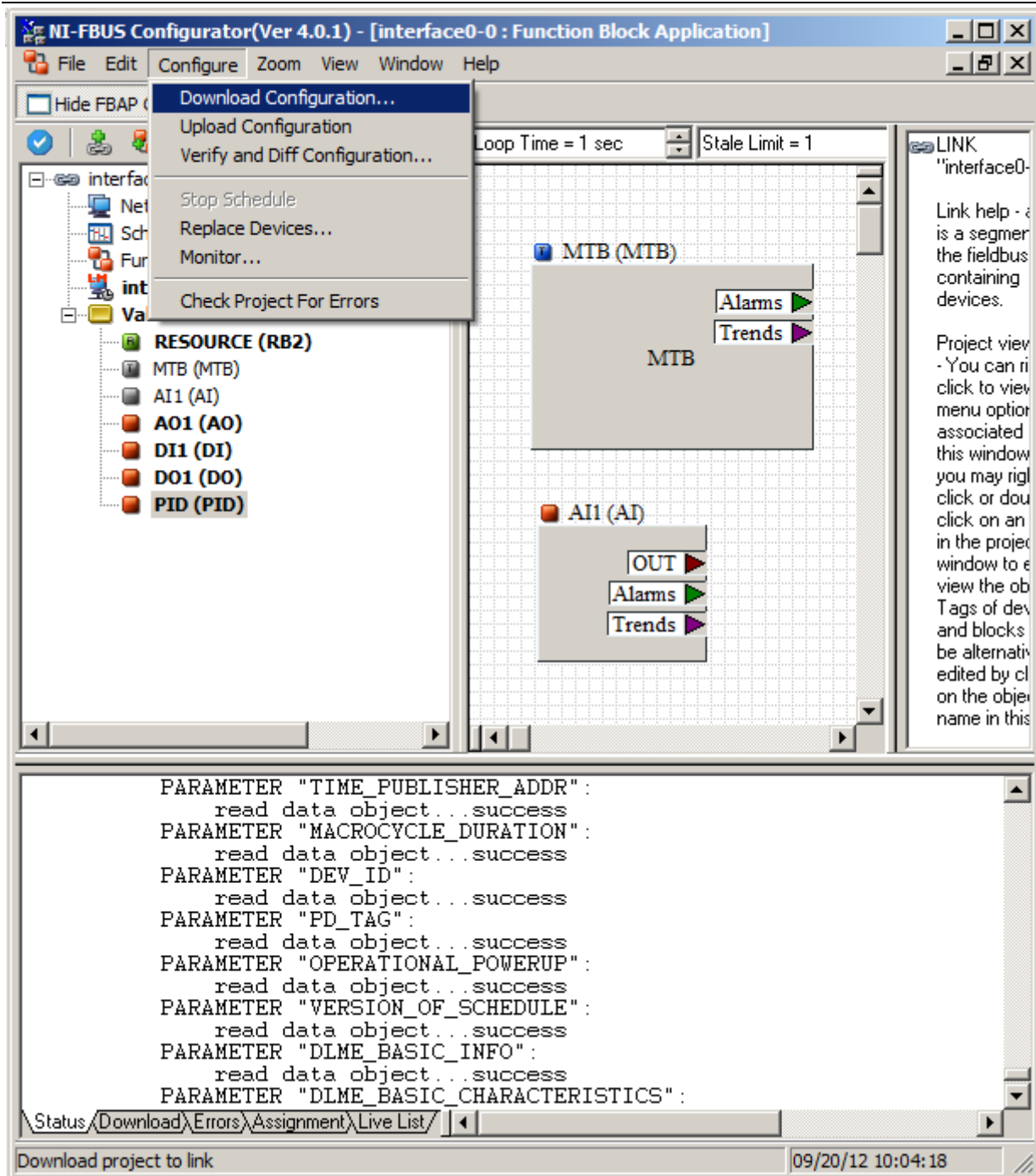

The screenshot shows the NI-FBUS Configurator (Ver 4.0.1) interface. The main window displays a configuration menu with options like 'Download Configuration...', 'Upload Configuration', and 'Verify and Diff Configuration...'. The project tree on the left shows a 'RESOURCE (RB2)' containing 'MTB (MTB)', 'AI1 (AI)', 'AO1 (AO)', 'DI1 (DI)', 'DO1 (DO)', and 'PID (PID)'. The main workspace contains two blocks: 'MTB (MTB)' and 'AI1 (AI)'. The 'MTB (MTB)' block has 'Alarms' and 'Trends' buttons. The 'AI1 (AI)' block has 'OUT', 'Alarms', and 'Trends' buttons. The bottom panel shows a list of parameters and their read data object status, all marked as 'success'.

```

PARAMETER "TIME_PUBLISHER_ADDR":
  read data object...success
PARAMETER "MACROCYCLE_DURATION":
  read data object...success
PARAMETER "DEV_ID":
  read data object...success
PARAMETER "PD_TAG":
  read data object...success
PARAMETER "OPERATIONAL_POWERUP":
  read data object...success
PARAMETER "VERSION_OF_SCHEDULE":
  read data object...success
PARAMETER "DLME_BASIC_INFO":
  read data object...success
PARAMETER "DLME_BASIC_CHARACTERISTICS":
  
```

Status: Download Errors Assignment Live List

Download project to link 09/20/12 10:04:18